

Press-Mounted Radial Typeholders

Radial Typeholders — for marking bar or tube ends, gears or marking on an arc

Round Typeholder

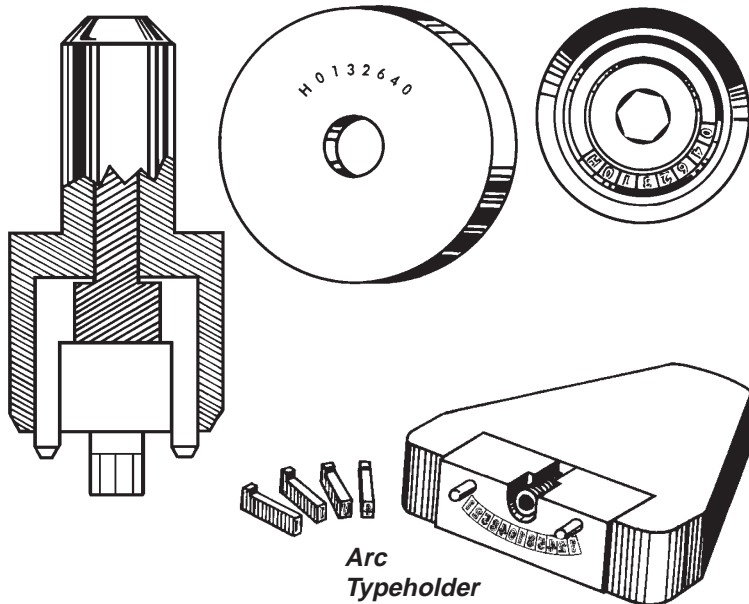

Wagner precision-built radial typeholders offer these advantages:

- Chip-proof, shock-resistance steel head
- Steel type for holder is precision-made, hardened and ground to 0.0005 tolerance to produce uniform impressions
- Custom typeholders and type to fit your particular application available. Send sample or drawing and impression of present steel type for quotation.

Round Typeholder

Designed for the particular part being marked, the Round Typeholder has a center pilot pin to locate text on a part at a given radius. Brand names and logotype can be reproduced in radial segments and code numbers added as individual type. Lettering can fill the typeholder's complete type cavity circumference.

Arc Typeholder

Also designed for the particular part being marked, the Arc Typeholder is for larger parts where text is stamped on only a section of the arc. The two pins locate lettering radially to center hole or edge of radius part.

Other Typeholder And Type Styles Available To Meet Specific Application Requirements

Direct Read Typeholder

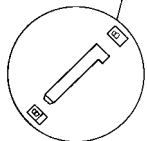
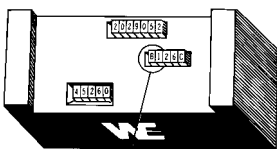

Direct reading typeholders permit direct text reading for easy, error-free typesetting.

Roll Die Typeholder

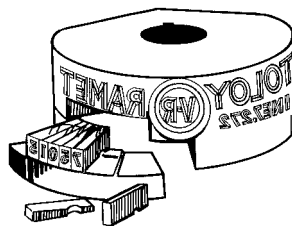

Roll die typeholders mark flat or round parts with less pressure.

Concave and Convex Type

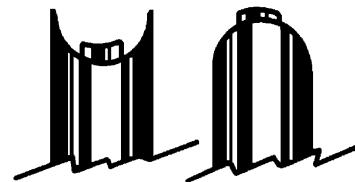

Concave and convex type allows marking on curved surfaces.

500 Clark Avenue, St. Louis, Missouri 63122-6401
Call us Monday through Friday between 7 am and 4 pm Central
314 / 821-3135 or toll-free 1-800 / 325-9474
Fax 314 / 821-0343, <http://www.wagnerengraving.com>

WAGNER
WE
ENGRAVING COMPANY